

Scanning HOT METAL DETECTOR

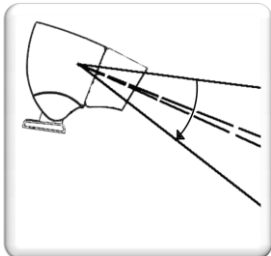

Rota-Sonde

DC4500



Smart display with Signal level

Easy alignment with Laser Line

Design for the most difficult applications

Very High Sensitivity 360 °F

Lt 1445 1



Presentation

The **Rota-Sonde DC4500** is a scanning sensor, which is sensitive to the infrared radiation emitted by hot products. It is a self-contained detector including:

- An optoelectronic case with heavy duty connector.
- A protecting hood with air purging.
- A cooling plate with an adjustable mounting stand.

Thanks to its design and particularly its cast aluminum housing, the **Rota-Sonde DC4500** is specially adapted for the harsh environment of the Steel Industry (shocks, vibrations, heat, vapor and dust).

Benefits

- High detection accuracy thanks to the narrow lateral field: independent of product temperature, size or position.
- Reliable detection even in the presence of steam or dust thanks to the small analyzing beam.
- Easy alignment of the sensor with integrated laser line (model -LL) or laser pointer (model -LP).
- Easy setup with integrated LED bar-graphs: signal amplitude and detection thresholds.
- Extensive diagnostic features including display of alarm and low detection margin signals.
- High sensitivity: 360 °F.
- 2 sensitivity ranges with on line selection.
- Shutter with 2 fixed apertures: 2 mm for usual applications and 0.7 mm for high temperature applications.
- Easy maintenance: very quick access to window glass, rapid exchange of the sensor.
- Direct replacement of DELTA models Rota-Sonde **DC3000** and **DC4000**.
- Remote setting and diagnostic with optional junction box **CR4500DC**, when access to sensor is not easy.

Applications

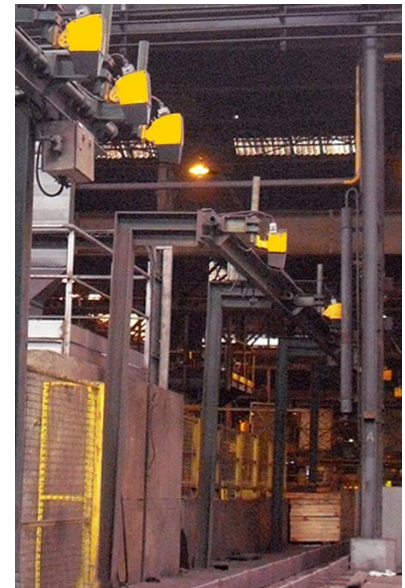

The **Rota-Sonde DC4500** is a scanning hot metal detector for rolling mill and continuous caster applications, offering two sensitivity ranges, two self-monitoring functions and a display with bargraph to help setup.

The "high sensitivity" range enables detection of steel product at a temperature as low as 360 °F. The **Rota-Sonde DC4500** is perfectly suitable for all detection applications of low-temperature rolled product or low emissivity materials such as hafnium, aluminum... It is also convenient for applications where a change in the process or material leads to major variations in the temperature of the product or its emissivity, as after quenching, or for special steels, etc...



Operating principle

Infrared Scanning for high detection accuracy:

The **Rota-Sonde DC4500** scans the infrared radiation emitted by hot products within a narrow lateral field with different angles of 10°, 30° or 50° depending on the model.

- Wide vertical detection field angle (up to 50°);
- Narrow horizontal detection field for very accurate detection;
- Small detection spot allowing installation at large distances from the product without reducing the sensor sensitivity.

Large infrared spectrum for high sensitivity:

The **Rota-Sonde DC4500** is designed with an infrared photocell having high sensitivity and wide spectrum wavelength range for sensing steel at temperatures as low as 300 °F; thus allowing reliable detection at a temperature of 360 °F.

All these features provide accurate and reliable detection, whatever the dimensions and the temperature of the product, or its distance and its position in the scanned field.

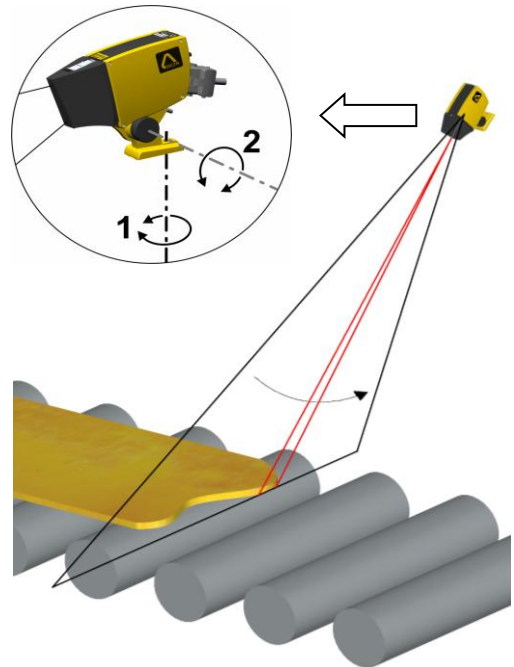

Construction

The **Rota-Sonde DC4500** is enclosed in sealed heavy duty aluminum housing and includes:

- A cooling plate with a stainless steel pipe for water cooling.
- A hood with air purging to protect the window glass. The hood is fitted with a draw latch for quick access to the window glass (DC451● and DC453●).
- A shutter with 2 apertures 2 mm and 0.7 mm.
- A mounting stand, which permits to adjust the position of the field of detection in two axes.
- Water and air purging connections are located on the support plate. In this way it is possible to remove the sensor without disconnecting the water and air supplies and without need of optical realignment.
- A heavy duty connector, including high temperature cable with protective steel braid.

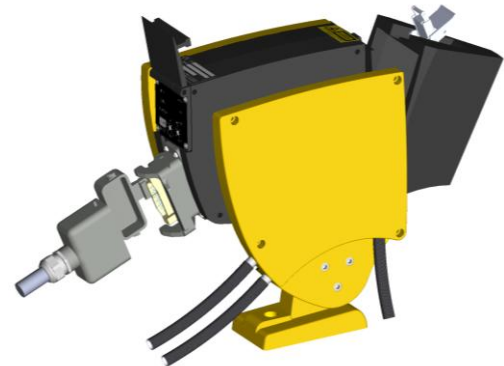

Alignment laser

The **Rota-Sonde DC4500** can be supplied with two types of laser:

- **Laser Line** (LL version): the laser shows the exact position of the detection field. This makes the alignment of the sensor in both directions easier.
- **Laser Pointer** (LP version): a laser pointer gives the lateral position of the field of detection.

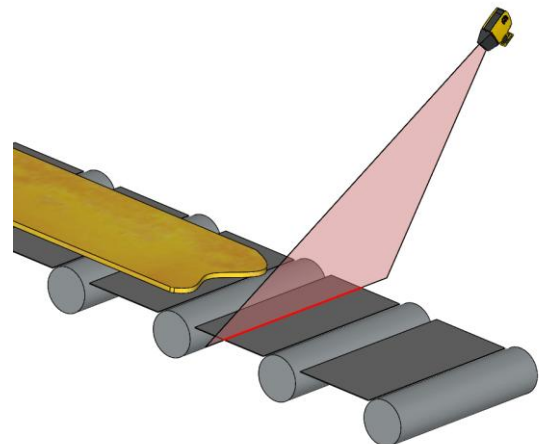



Extended setting and diagnostic functions

Control panel protected by a flip cover:

- **Two bar-graphs:** one for live level of photocell signal (green LED). The other (blue LED) for information on threshold (THR.) setup.
- **Two sensitivity setting potentiometers** (one for each range) with blue LED indicating which one is active.
- A **LASER / TEST** button: to switch On/Off the laser for alignment. To initiate a test (press during 3 sec). This test can also be activated remotely.
- Three LED for **sensor status**.



Self-monitoring functions:

In order to optimize preventive maintenance and to improve reliability, the **Rota-Sonde DC4500** includes:

- **ALARM** output and LED: this signal is activated when there is an internal failure of the sensor: Internal temperature too high (limit of 130 °F), scanning system or electronics board failure.
- **CONTROL** output and LED: this signal is activated when the detection margin is not sufficient (2 LED on the bar-graph). This is an indication that the window glass is getting dirty or that the background is becoming too hot. It is activated also in case of incorrect sensitivity setting.
- Remote **test** function.

Technical characteristics

Optics

Model	DC451●-●●	DC453●-●●	DC455●-LP
Scanning angle (1)	10°	30°	50°
Response time	1 ms	2 ms	4 ms
Sensitivity with 2 mm shutter (2)	High sensitivity range: 430 °F (220 °C) Normal sensitivity range: 750 °F (400 °C)		
Sensitivity shutter removed (2)	High sensitivity range: 360 °F (180 °C)		
Spectrum sensitivity	1 to 2.6 μm with maximum sensitivity at 2.2 μm		

(1) The scanning angle can be reduced using shutters. Refer to the chapter "Accessories".

(2) The temperature is specified for an emissivity over 0.8 and for a product size covering more than 10% of the field of view in the scanning direction.

Model	DC45●●-LL	DC45●●-LP
Laser pointer	Laser line corresponding to the scanned field (3)	Laser pointer
Laser class (IEC-60825-1)	Class 2M, red	Class 2, red



(3) Available for DC4510 and DC4530.

Distance between sensor and product

	Low temperature application	Standard application
Wire	0.1 to 0.5 m	0.3 to 2 m
Bar	0.3 to 1 m	0.5 to 6 m
Billet - Bloom	0.5 to 2 m	1 to 10 m
Slab - Strip - Plate	2 to 4 m	3 to 20 m



Electrical and other characteristics

Model	DC45•0••	DC45•6••
Product Presence (P.P.) Relay output or Static Relay Output	<i>Relay output:</i> Single pole changeover; Switching capacity: 550 VA - 250 V - 5 A max Closing time: 7.5 ms; Opening time: 3 ms	<i>Static Relay output:</i> Two optocoupled complementary Solid State Relay outputs; Impedance 50 Ω; Switching capacity: +/- 350 V peak, +/- 100 mA peak
Product Presence (P.P.) Static outputs (S /S)	Push-pull complementary outputs Low impedance: 0 / 24 V - 50 mA, protected against short circuit	
Alarm output (ALARM)	Push-pull output - Low impedance: 0 / 24 V - 50 mA, protected against short circuit 0 V: sensor failure 24 V: sensor ok	
Control output (CONTROL)	Push-pull output - Low impedance: 0 / 24 V - 50 mA, protected against short circuit 0 V: detection margin insufficient 24 V: detection margin ok	
Selection N/H input	0 / 24V - 1mA 0 V : High sensitivity range 24 V (open): Normal sensitivity range	
Test input	0 / 24V - 1mA 0 V: test 24 V (open): normal operation	
Signal Amplitude output	0 to 15 V, analogue voltage proportional to the photocell signal	
Sensitivity input	0 to 15V - 3mA or external 10k potentiometer to 0V 0V: highest sensitivity, 15V: lowest sensitivity, open: control panel setting	
Connection - cable	Connector fitted with silicone cable with protective steel braid Standard length 2 m (other length: 3, 5 or 8 m)	
Protecting rating	IP 66 (cast aluminum case)	
Air purging	Instrument air: 0.05 to 0.2 bar, flow rate: 4 to 16 l/min	
Operating ambient temperature	0 °F to 140 °F (-20 °C to 60 °C) without cooling, Up to 250 °F (120 °C) with water cooling: industrial quality water at about 77°F (25 °C), pressure 1-2 bar and flow 1-5 l/min	
Weight	7 kg	
Operating voltage	220 V (-10%) to 240 V (+10%) - 50/60 Hz or 110 V (-10%) to 120 V (+10%) - 50/60 Hz	24 VDC (18 to 30 VDC)
Power consumption	30 VA	< 600 mA

Connection

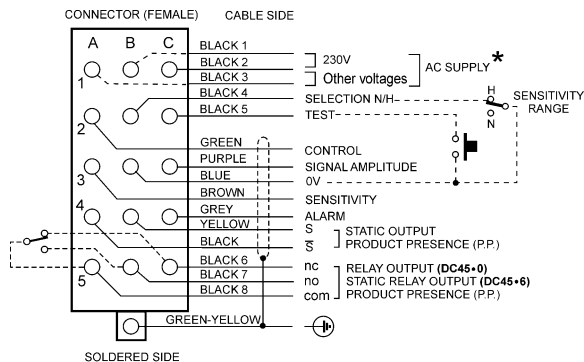

*NOTE: CABLE IS SUPPLIED WITH CONNECTIONS FOR THE VOLTAGE REQUESTED.

AC supply

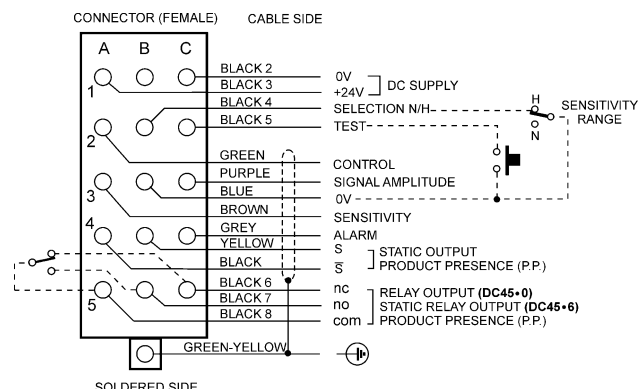

DC supply



Dimensions

DC451• and DC453•

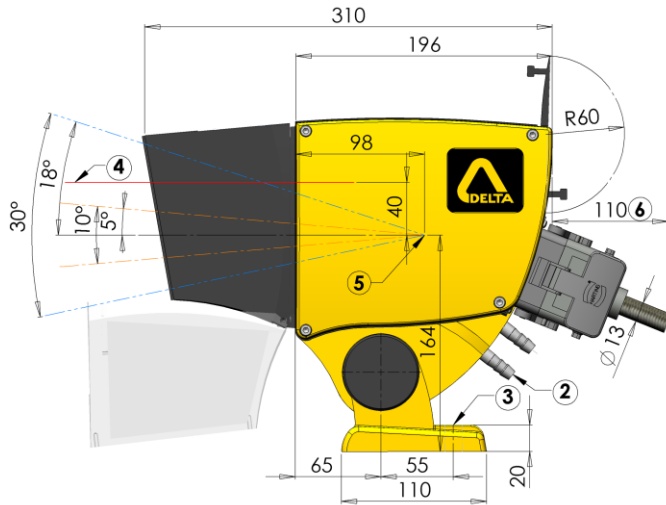

DC455•

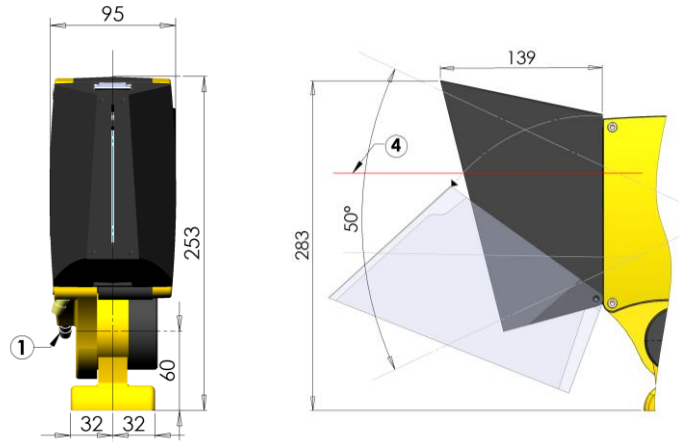

- ① Air supply \varnothing 10
- ② Water supplies \varnothing 10
- ③ Mounting with screw \varnothing 12
- ④ Laser pointer (-LP version)
- ⑤ Optical center
- ⑥ Connector clearance

Reference for order

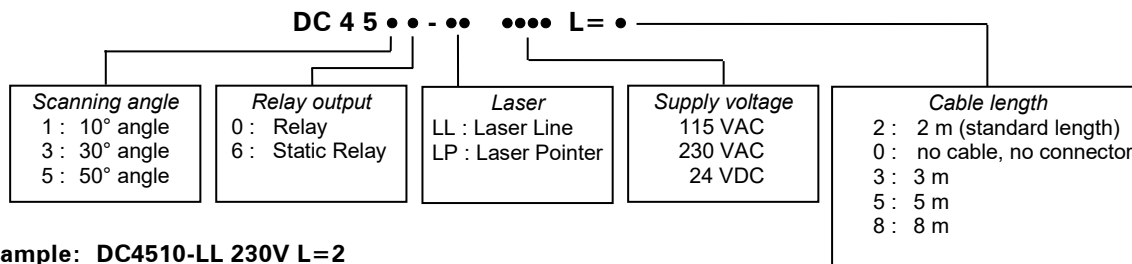

Example: DC4510-LL 230V L=2

Note: LL version not available for 50° scanning angle

Accessories

- Radiant bar **BR4000** for simulation of hot product (battery powered)
- **Shutters** to reduce the detection field angle: the scanning angle can be adjusted for application where it is necessary to avoid the detection of nearby hot metal - ref: 7193016
- **Heat Shield** to protect sensor from direct radiation - ref: 7592576 (not available for 50° scanning angle).
- Junction box **CR4500DC** for remote settings and diagnostics

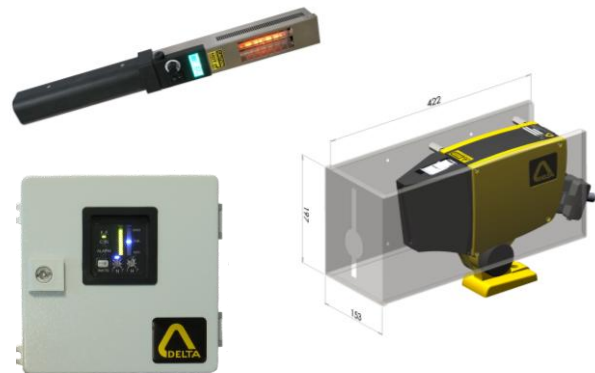

DELTA SAS
 Tel. +33 388 78 21 01 - info@deltasensor.eu - www.deltasensor.eu

DELTA SENSOR (CHANGZHOU) Co., Ltd. (China)
 Tel: +86 519 8188 2500 - info@deltasensor.com.cn

DELTA Vertriebsgesellschaft mbH (Germany)
 Tel: +49 700 3358 2736 - info.de@deltasensor.eu

DELTA SENSOR Pvt. Ltd. (India)
 Tel: +91 11 4054 8170 - info@deltasensor.co.in

DELTA USA INC. (North America)

CARNEGIE OFFICE PARC - BUILDING 2, SUITE 180
 600 NORTH BELL AVENUE, CARNEGIE, PA 15160

Tel: (412) 429 3574 Fax: (412) 429 3348
 info@delta-usa.com www.delta-usa.com

Subject to change without prior notice

Lt 1445 **6**