



Through-Beam LASER BARRIER

Laser Barrier

VL/VRG



Detection of hot or cold products

Visible laser beam

Models with alarm signal

Designed for harsh environment



80 m

Lt 962



Special Features

- Intense, highly directive, visible red laser diode beam.
- Insensitivity to ambient light.
- Adjustable sensitivity.
- A LED indicator showing operation of the receiver.
- Air purging.
- Optional water-cooling jackets for use at ambient temperatures higher than 50 °C (122 °F).
- Alarm signal, when the lenses become too dirty or when the internal temperature is too high.
- Modular construction allowing rapid maintenance.
- Optional features allowing configuration for any application.

Typical applications

The **Laser Barrier VL/VRG** resolves all detection problems that may arise in the most diverse types of industry, for example heavy industry (steel), handling and transport, etc. It is particularly recommended for the following applications:

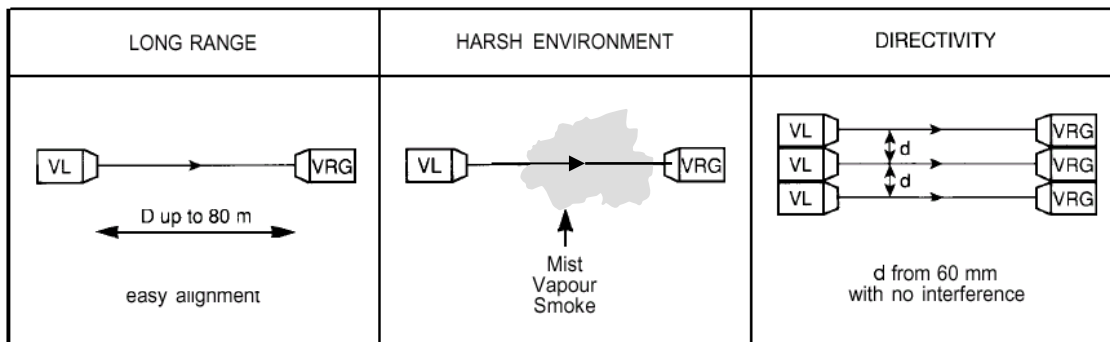

The emitter **VL** unit emits a high intensity, visible beam of modulated red laser light. This beam is received by a photosensitive diode fitted with an optical filter and whose signal is processed by the incorporated circuitry of the receiver **VRG**. The output changes state depending on whether the modulated beam is interrupted or not. Beam modulation, special optical filter and automatic correction make the sensor insensitive for ambient light.

Commissioning and Alignment

The visible, intense and highly directive laser beam makes the setting up of the optical barrier **VL/VRG** simple and rapid.

To align the sensor, use the following procedure:

- Mount the **VL** emitter and adjust its orientation while at the same time observing the point of impact of the beam on the product to be detected.
- Observe the impact of the laser beam on a target near the **VRG** receiver.
- Position the receiver so as to center the beam on its lens.
- Set the receiver sensitivity potentiometer to maximum.
- Turn the receiver about its axis in order to find the extreme positions where the output changes state.
- Fix the receiver in the central position between these two extremes.

This procedure guarantees a precision for the detection of approx. 1 cm for a product of cross-section greater than 4 cm.

The accuracy of the detection can be increased by optimizing the detection threshold adjustment with the sensitivity potentiometer.

Performance specifications

Maximum distance between emitter and receiver	80 m
Detection accuracy	For 2 m product/sensor distance: ± 1.5 mm For 6 m product/sensor distance: ± 5 mm

Emitter

Reference	VL
Emitted power / Laser class	1 mW / Class II (FDA 21 CFR 1040), Class 2 (IEC 60825-1)
Wave length	635 - 670 nm
Divergence	Typ. 1 mrad



Laser Class 2

Lt 962 2



Receiver

Model	VRG - ••• S Transistor Output	VRG - ••• SR • Isolated solid state relay output	VRG - ••• R • Relay Output
Electrical characteristics	2 complementary push-pull outputs, short circuit protection, Low impedance : 0/24 V - 100 mA max.	2 Optocoupled complementary Solid State Relay : Impedance : 50 Ω Switching capacity +/- 350 V peak +/- 100 mA peak	Single pole changeover Switching capacity : 230 V a.c. – 2.5 A a.c.
Response time	1 ms		Make time : 8 ms Break time : 4 ms
Alarm	Push-pull output, short circuit protection, 0/24 V - 50 mA max (not available for VRG - • C - R and VRG - • C - SR with AC supply voltage) 0V if received light too low or internal temperature > 50 °C		

Model	VRG - ••• S	VRG - ••• R1 – VRG - ••• SR1	VRG - ••• R2 – VRG - ••• SR2
Operating mode	S output at 24 VDC and LED on when the beam is interrupted.	Dark: relay energized and LED on when the beam is interrupted.	Light: relay energized and LED on when the beam is not interrupted.
LED indicator	Off: Beam not interrupted Green: Beam interrupted Red: Alarm, beam not interrupted Orange: Alarm, beam interrupted	Off: Beam not interrupted Green: Beam interrupted Red: Alarm, beam not interrupted Orange: Alarm, beam interrupted	Off: Beam interrupted Green: Beam not interrupted Red: Alarm, beam interrupted Orange: Alarm, beam not interrupted

Other data and dimensions:



Operating voltage	220 V (-15%) to 240 V (+10%) - 50 / 60 Hz or 110 V (-15%) to 120 V (+10%) - 50 / 60 Hz or 24 V (±10%) - 50 / 60 Hz	24 V DC (±20%)
Power consumption	10 VA	8 W
Connection	Terminal block – 2 PG 9 (VL/VRG - •• B - •••) Connector fitted with silicone cable with protective steel braid (VL/VRG - •• C - •••) Standard length of 2 m (other length: 3, 5 or 8 m)	
Weight	5 kg (VL/VRG - JC - ••) – 3.6 kg (VL/VRG - LB - ••)	
Protection rating	IP 67 (cast aluminium case)	
Air purging	Protection of the optic with clean air : 50 to 200 g/cm ² , 4 to 16 l/min	
Working temperature	-10 to 50 °C (14 to 122 °F) without cooling Up to 120 °C (250 °F) with water cooling: industrial quality water at about 25 °C (77 °F), pressure 1-2 bar and flow 1-2 l/min	

VL - LB
VRG - LB - •

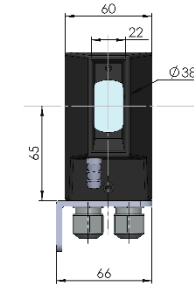
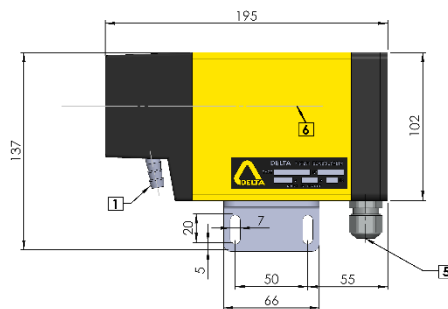

VL - JC
VRG - JC - •

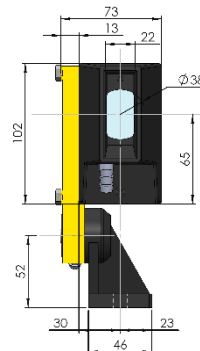
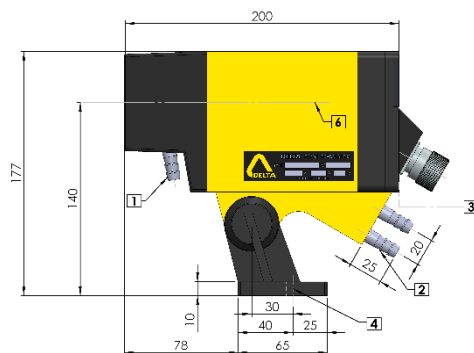

- 1 Air supply Ø 10
- 2 Water supplies Ø 10
- 3 Connector clearance 90 mm
- 4 Mounting with screw Ø 10
- 5 Cable glands (2) for cable with Ø 7-10,5 mm
- 6 Optical axis



Connection

VL - - -

VRG - - - - S

VRG - - - - R •
VRG - - - - SR •

Connection via connector (VL/VRG - - C - -)

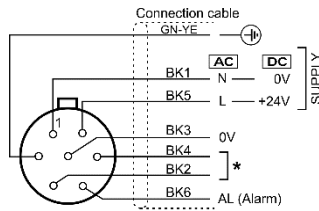

* Do not connect to any voltage.

Connection via terminal block (VL/VRG - - B - -)

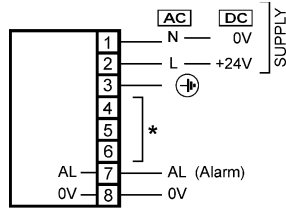

* Do not connect to any voltage.

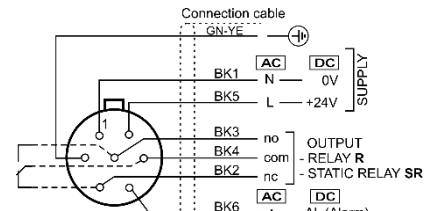
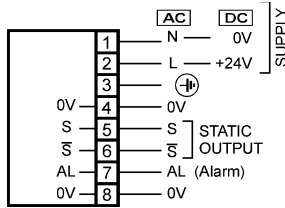
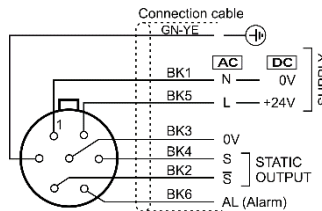

* Do not connect to any voltage.

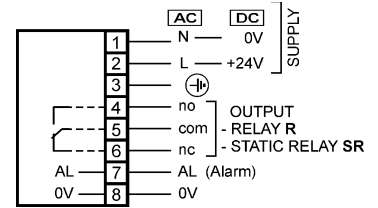

Order reference

CASE	MOUNTING	CONNECTION	OUTPUT	SUPPLY VOLTAGE
	L Bracket	B Terminal block	S Solid-state	230 V AC 115 V AC 24 V AC 24 V DC
			SR1 SR2 Opto solid-state relay	
	J Mounting stand and cooling jacket	C Connector	R1 R2 Relay	

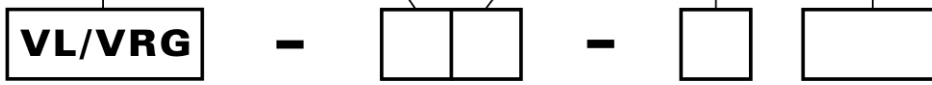

E.g. : VL/VRG-JC-R1 230V AC

DELTA

Tel : +33 388 78 21 01 - Fax : +33 388 76 02 29
info@deltasensor.eu - www.deltasensor.eu

DELTA Sensor (China)

Tel: +86 519 8188 2500 - Fax: +86 519-8188 2400 - info@deltasensor.com.cn

DELTA Vertriebsgesellschaft mbH (Germany)

Tel: +49 700 3358 2736 - Fax: +49 700 3358 2835 - info.de@deltasensor.eu

DELTA Sensor (India)

Tel: +91 11 4054 8170 - Fax: +91 11 4054 8172 - info@deltasensor.co.in

DELTA Sensor (Russia)

Tel: + 7 916 682 6027 - info.ru@deltasensor.eu

DELTA USA INC. (North America)

CARNEGIE OFFICE PARC - BUILDING 2, SUITE 180
600 NORTH BELL AVENUE, CARNEGIE, PA 15160

Tel: (412) 429 3574 Fax: (412) 429 3348
info@delta-usa.com www.delta-usa.com

Subject to change without prior notice

Lt 962 4